

**A multi-step algorithm for serial order:
Converging evidence from Linguistics and Neuroscience**

Cedric Boeckx^{1,2} & Anna Martínez-Álvarez²
¹ICREA & ²Universitat de Barcelona

The present contribution aims to explore how serial order is computed in the human mind/brain from a biolinguistic perspective (Lenneberg 1967; Chomsky 2005; Di Sciullo et al 2010). To do so, the process of linearization is decomposed into three different computational mechanisms described in a way that allows their implementation in the human brain. Departing from a subdivision of Broca's area into three different areas: pars opercularis, pars triangularis and frontal operculum (Friederici *et al.* 2003). The present work claims that these three brain areas play an important role in Language and, in particular, in the process of linearization converging with DM.

As Lashley 1951 pointed out, “the problems raised by the organization of language seem to me to be characteristic of almost all other cerebral activity. There is a series of hierarchies of organization; the order of vocal movements in pronouncing the word, the order of words in the sentence, in a discourse. Not only speech, but all skilled acts seem to involve the same problems of serial ordering”. Lashley’s concern with serial order was also shared by Richard Kayne. Approaching serialization of hierarchical organization from a linguistic perspective, Kayne (1994) proposed that linearization is a one-step process, that is, hierarchical relations give rise to linear order directly, via is Linear Correspondence Axiom.

The theoretical framework of Distributed Morphology (DM) assumes that syntax itself generates and manipulates an unordered hierarchy of abstract syntactic features devoid of phonological content, the so-called “morphemes” (Halle and Marantz 1993). The phonological content of a morpheme is inserted postsyntactically. Unlike for Kayne, in DM linearization would consist of a series of processes that realize the phonological content of a hierarchical representation. Following the tenets of DM, Idsardi and Raimy (in press) offer a decomposition of the process of linearization into three different operations, as shown in (1):

(1) Linearization processes

<u>Module</u>	<u>Characteristics</u>
<i>Narrow syntax</i> LINEARIZATION-1 = Immobilization	hierarchy, no linear order, no phonological content
<i>Morphosyntax</i> LINEARIZATION-2 = Spell-out	hierarchy, adjacency, no phonological content
<i>Morphophonology</i> LINEARIZATION-3 = Serialization	no hierarchy, directed graph, phonological content
<i>Phonology</i>	no hierarchy, linear order, phonological string

In parallel to this development in linguistics, the functional role of Broca's area has been a focus of debate in the neurolinguistic field since a very long time (Grodzinsky and Santi 2008; Rogalsky & Hickok 2011; a.o.). With the spread of neuroimaging techniques, advances regarding Broca's area have been made in the neuroscientific field. Broca's area consists of three different areas, namely pars triangularis (BA 44), pars triangularis (BA45) and the adjacent frontal operculum. The neural connectivity between Broca's areas and the temporal lobe is recently summarized in Rogalsky and Hickok (2011) and shown in (2):

(2)

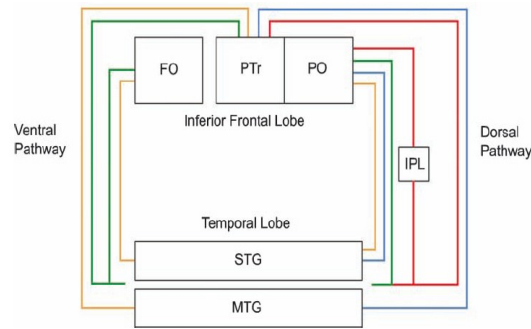

Following the lines of current neurocognitive models of language processing (Friederici 2011) which assume fronto-temporal networks supporting different syntactic and semantic aspects during language processing, the present contribution is based on three distinct networks shown in (2) implicated in three linguistically-established computational subroutines, as shown in (1). The multi-step algorithm for serial order sketched so far is not only “theoretically motivated” and “computationally explicit” (Poeppel and Embick 2008) but also “biologically grounded”. More specifically, (i) the dorsal pathway connecting PO and the temporal lobe is implicated in linearization process 1 (immobilization), (ii) the ventral pathway running from PTR to the temporal lobe is involved in linearization process 2 (spell-out), and (iii) the ventral pathway relating FO with the temporal lobe is associated to linearization process 3 (serialization).

If this contribution is on the right track, functionally and anatomically different pathways subserve specific types of computations. Different cortical areas are thus specialized for performing distinct types of computations, some of which are necessary for language operations (in this case, types of linearization), but also for other cognitive functions. This perspective contributes to a further understanding of linguistic phenomena such as linearization and sheds some light to the study of the Language Faculty implemented in the human brain.

This study also highlights the need to decompose Broca's areas and the linearization algorithm in parallel, a significant departure from standard practice in both linguistics and neuroscience.

References Chomsky, N. 2005. Three Factors in Language Design. *Linguistic Inquiry* 36: 1–22. Di Sciullo et al. 2010. The Biological Nature of Human Language. *Biolinguistics* 4:4–34. Friederici, A.D., et al. 2003. The role of left inferior frontal and superior temporal cortex in sentence comprehension: localizing syntactic and semantic processes. *Cerebral Cortex* 13(2), 170–177. Friederici, A.D. 2011. The brain basis of language processing: from structure to function. *Physiological Reviews* 91, 1357–1392. Halle, M. & A. Marantz. 1993. Distributed Morphology and the pieces of inflection, in K. Hale & S. Keyser (eds.), *The View from Building 20*, MIT Press, 111–176. Idsardi, W.J. & E. Raimy. 2010, in press. Three types of linearization and the temporal aspects of speech. In T. Biberauer & I. Roberts (eds.) *Principles of linearization*. Mouton de Gruyter. Kayne, R. 1994. *The Antisymmetry of Syntax*. MIT Press. Lashley, K.S. 1951. The Problem of Serial Order in Behavior. In Beach et al (eds.) *The Neuropsychology of Lashley*. McGraw-Hill. Lenneberg, E.H. 1967. *Biological Foundations of Language*. Wiley. Poeppel, D & D. Embick. 2005. Defining the Relation Between Linguistics and Neuroscience. In A. Cutler (ed.) *Twenty-First Century Psycholinguistics*. Lawrence Erlbaum. Rogalsky, C. & G. Hickok. 2011. The role of Broca's area in sentence comprehension. *Journal of Cogn Neuroscience* 23(7), 1664–1680.